

imagine  
extraordinary

ES | Legacy

An aerial photograph of a large industrial or manufacturing complex. In the foreground, a large, colorful, abstract sculpture resembling a rainbow flag stands in a landscaped area. The background shows several large, white industrial buildings with flat roofs, some with solar panels. The sky is clear and blue.

# A Culture of Quality and Innovation since 1983

For over 40 years, ES has redefined what's possible in residential design. We craft high-performance windows and architectural systems that seamlessly blend striking aesthetics with exceptional durability and energy efficiency. Our solutions are designed to elevate every space—offering expansive views, smooth indoor-outdoor transitions, and industry-leading thermal and acoustic performance.

With vertically integrated manufacturing and an uncompromising focus on quality, every product meets the highest standards of design, performance, and reliability. Whether you're building a dream home or leading a landmark project, ES turns bold visions into lasting realities.

# Timeless Design Meets Modern Performance

A modern interior space featuring a large window with a view of a dry, hilly landscape. The room includes a desk with a lamp and a chair.

The Legacy Line represents the pinnacle of architectural innovation, seamlessly integrating refined aesthetics, advanced engineering, and superior performance. Designed for visionary architects and developers, this luxury collection redefines the boundaries of contemporary design with precision-crafted windows and doors that elevate the built environment.

Every detail in the Legacy Line is meticulously engineered to meet the highest standards of thermal efficiency, structural integrity, and design versatility. With narrow sightlines, premium finishes, and cutting-edge thermal break technology, this collection ensures optimal performance without compromising on architectural expression.

# Architectural Elegance Redefined

Slim sightlines. Minimalist forms that elevate space with quiet confidence and refined precision.

We offer 1/4" thick lites always as a standard — Your comfort is our priority.



## Thermal Comfort, All Year Long

Advanced Thermal Break Technology delivers equilibrium within—cool when it's warm, warm when it's cool. Always composed.

Glass comes tempered as standard for strength. Your safety is not an upcharge.



## Engineered for Modern Living

Acoustic purity that honors the stillness great architecture deserves.

All products can have laminated glass included for sound and security - Peace of mind at a reasonable price finally. Safe and sound.



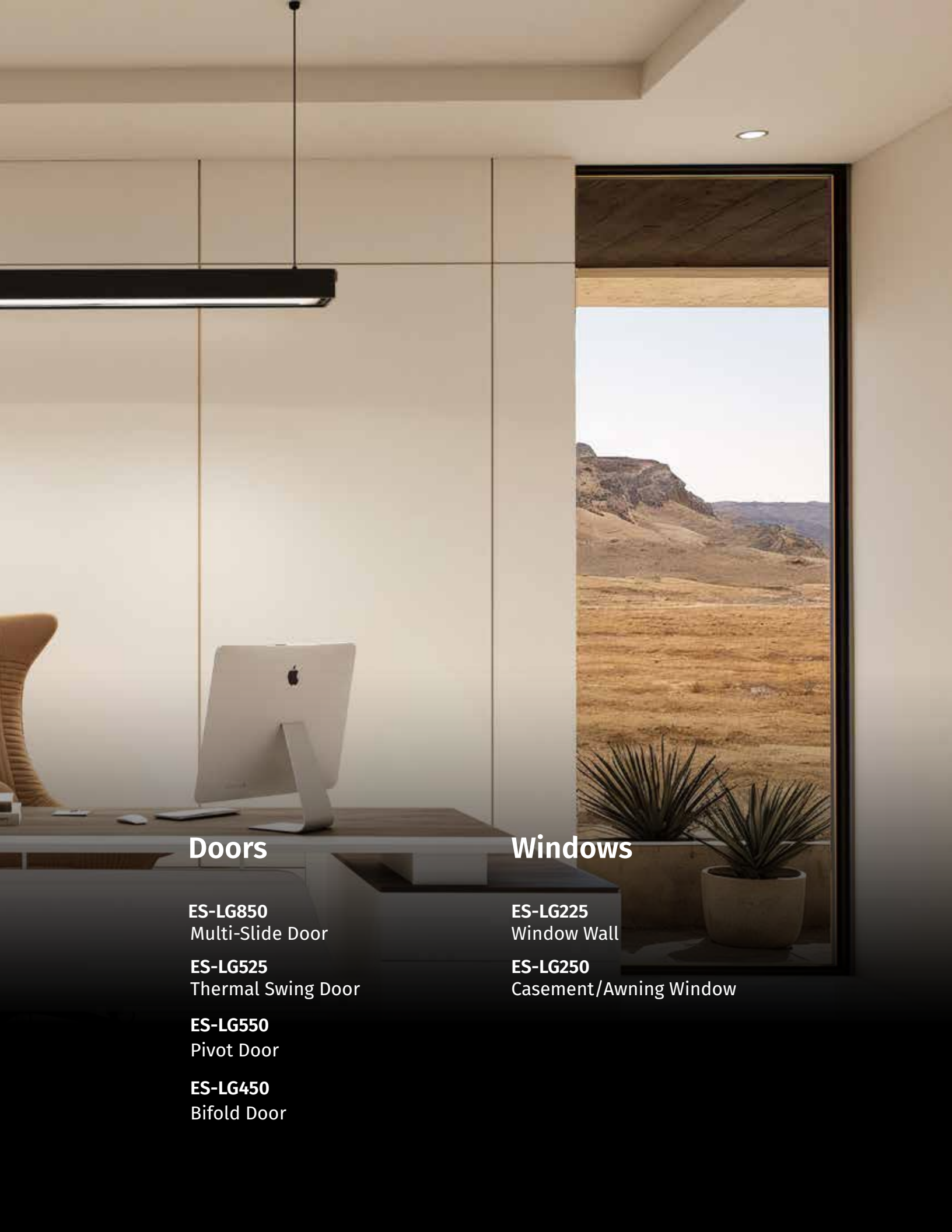

## Doors

**ES-LG850**  
Multi-Slide Door

**ES-LG525**  
Thermal Swing Door

**ES-LG550**  
Pivot Door

**ES-LG450**  
Bifold Door

## Windows

**ES-LG225**  
Window Wall

**ES-LG250**  
Casement/Awning Window

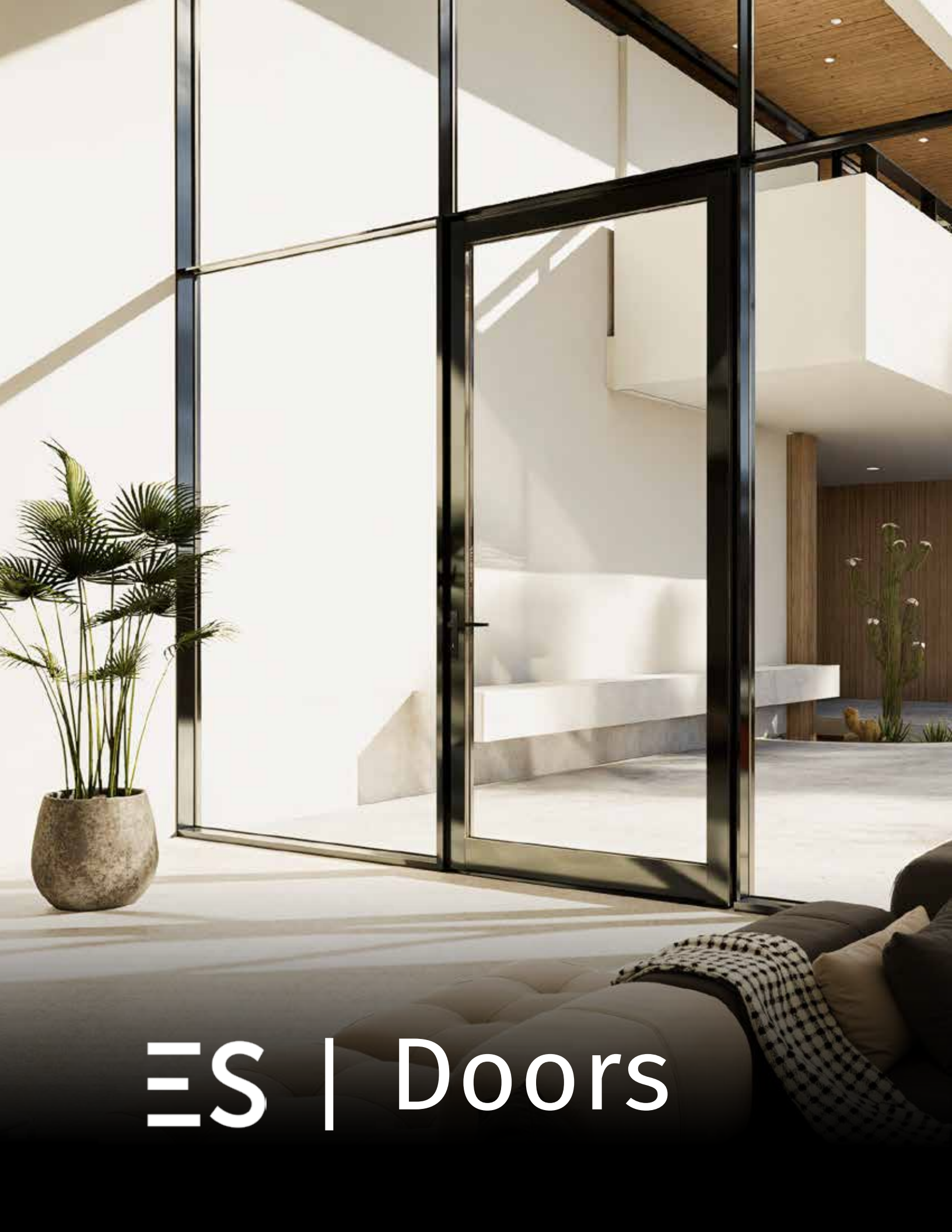

ES | Doors

# Doors That Elevate the Everyday





# ES-LG850

## Multi-Slide Door

A fully thermally broken system with seamless operation, slim sightlines, and expansive glass panels. The add-a-track design unlocks endless configurations—merging performance with panoramic elegance.



### Performance & Highlights

- Multi-slide door system
- Maximum sizes:
  - 72" width x 120" height
  - 84" width x 108" height
- Frame depth:
  - 2 track: 4-3/8"
  - 3 track: 6-9/16"*\* Customized tracks available*
- Sightline: 1-1/8"
- Designed for 1-1/8" insulating glass
- U-Value: as low as 0.27

### Features

- Fully thermally broken system
- Sill options of flush, water barrier, ADA and thinline available
- Stucco return nail fin 1" and 1-3/8"
- Standard flush handle and a contemporary handle option available
- With available pocketing, 90 degree, and biparting configurations
- Anodized, painted, and woodgrain finishes available

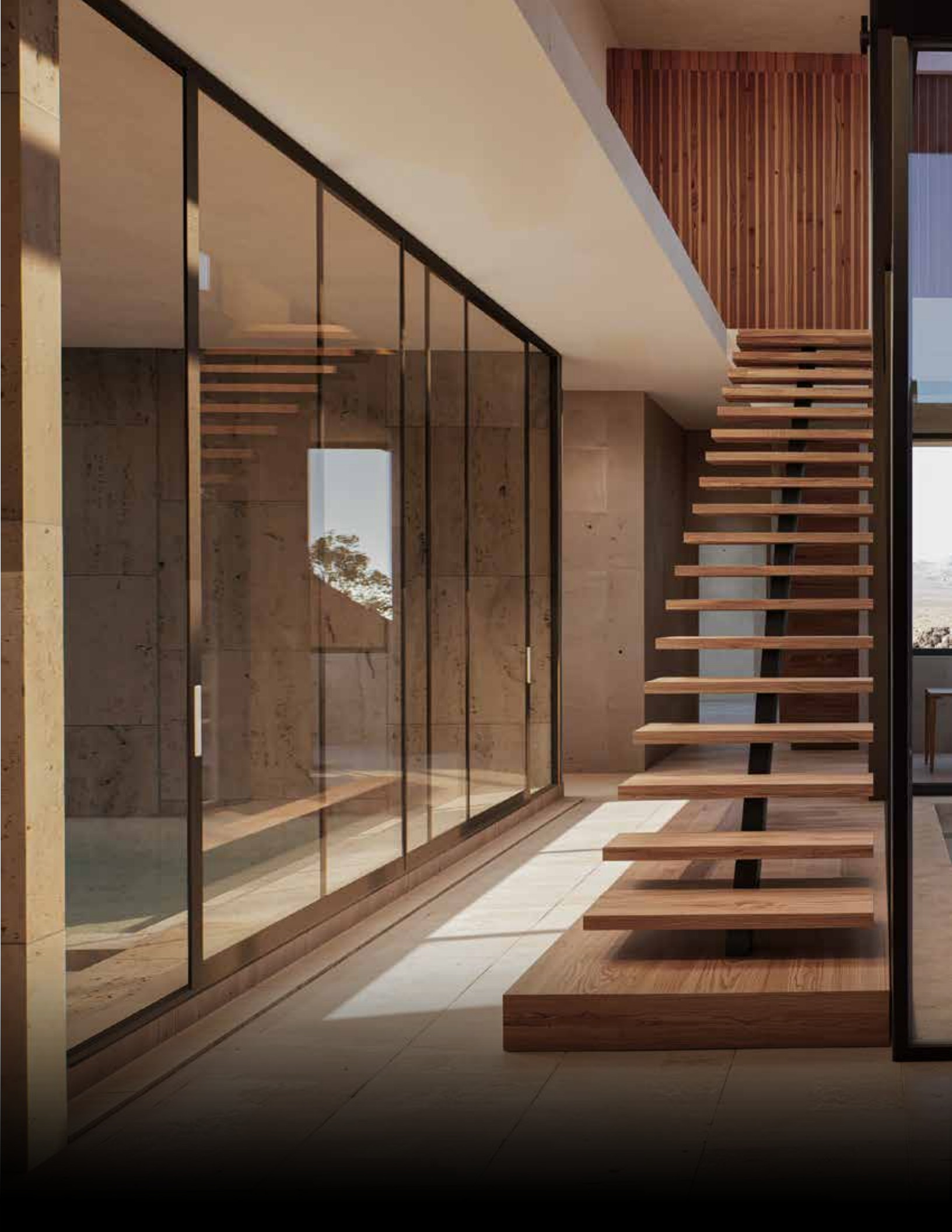

# ES-LG850

## Multi-Slide Door



Learn More

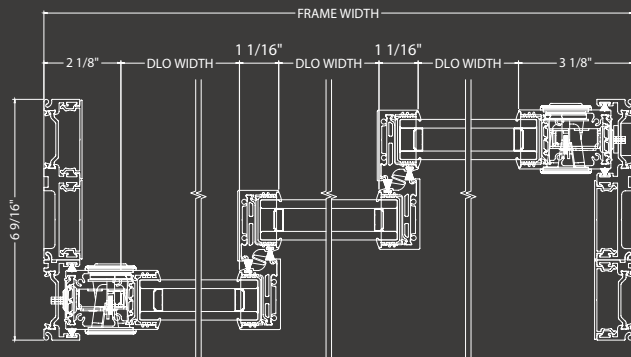

Lock Style Flush Handle

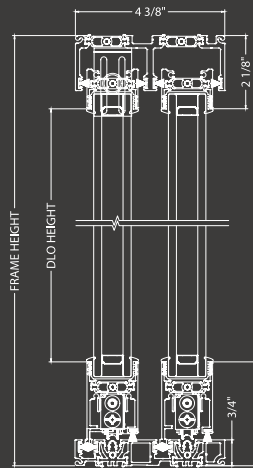

Flushsill

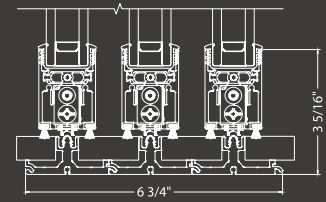

Thinline

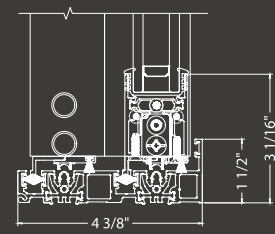

Watersill

### Technical Details

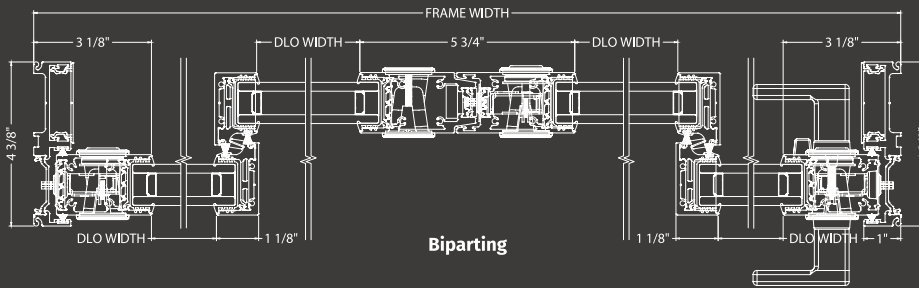

Biparting

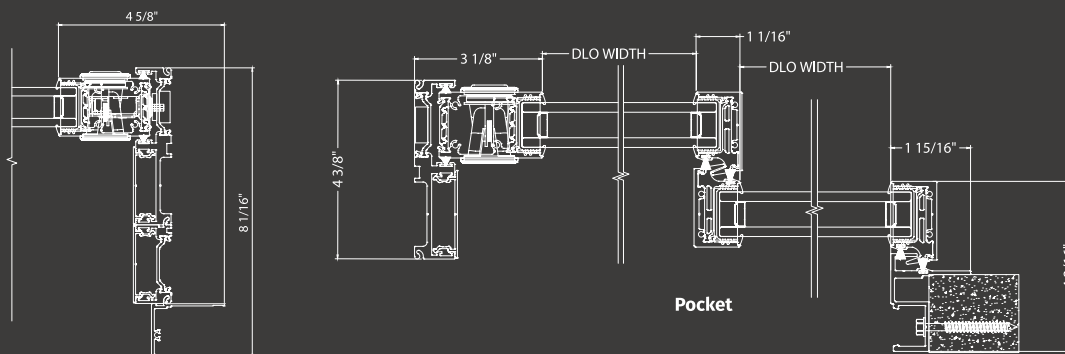

Pocket

Stucco Return

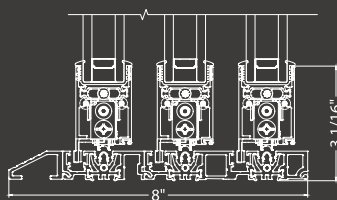

ADA Adaptor

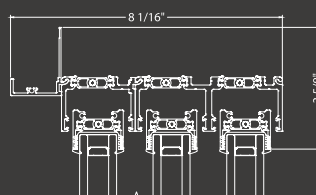

Head Stucco Return Nail Fin



# ES-LG525

## Thermal Swing Door

A statement of strength and style. This thermally broken swing door pairs refined design with advanced sealing and locking systems—offering elegance, security, and energy efficiency in one seamless entrance.

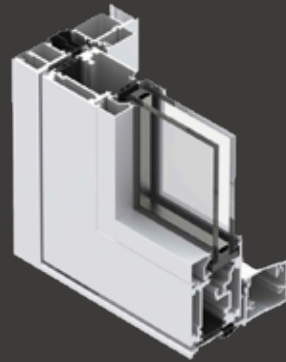

### Performance & Highlights

- Thermal inswing and outswing door
- Frame depth: 4-1/2"
- Maximum sizes:
  - Single: 48" width x 120" height
  - Double: 96" width x 120" height
- Sightline: 3-3/4"
- Designed for 1", 1-1/4", 1-3/16" insulating glass and 1 9/16" double insulating glass
- U-Value: as low as 0.27

### Features

- Standard and 5 Multipoint lock options
- Peak handle available
- Hager mortise hinge for inswing
- Anodized, painted, and woodgrain finishes available



# ES-LG525

## Thermal Swing Door



Learn More

### Out-Swing Configuration

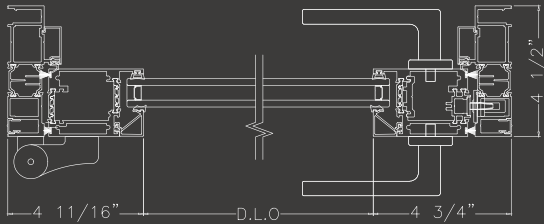

Jamb at Swing Out

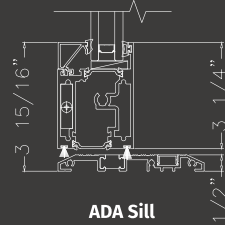

ADA Sill

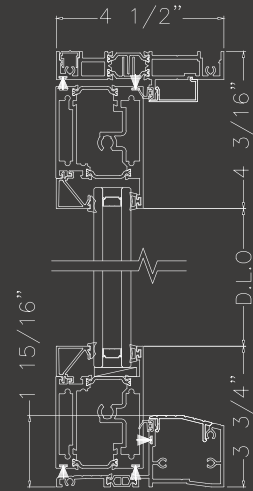

Head and Sill

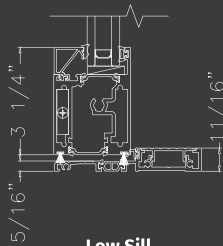

Low Sill  
No Water Rating

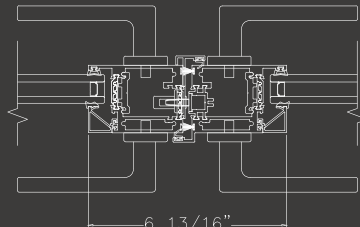

Astragal

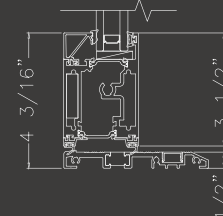

Low Sill

### In-Swing Configuration

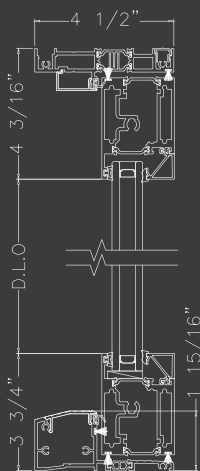

Head and Sill

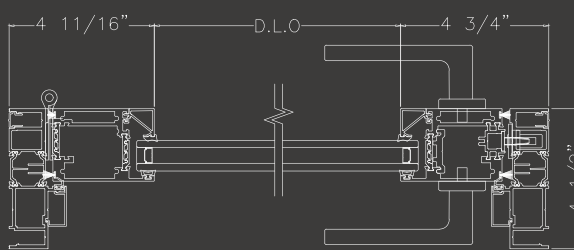

Jamb at Swing Out

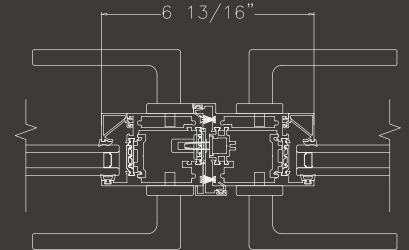

Astragal

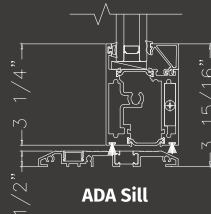

ADA Sill

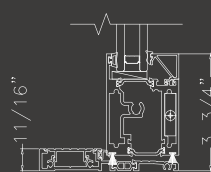

Low Sill

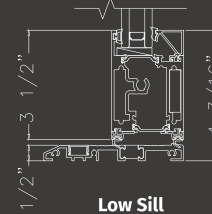

Low Sill  
No Water





# ES-LG550

## Pivot Door

Bold by design, refined in motion. Our new pivot door features a concealed hinge system that delivers seamless, effortless operation while redefining the modern entryway with striking simplicity. The concealed pivot hinge disappears into the frame allowing the door to glide effortlessly while maintaining a clean, uninterrupted aesthetic.



### Performance & Highlights

- Thermal pivot door
- Frame depth: 4-1/2"
- Maximum size: 72" width x 144" height
- Sightline: 4-3/4"
- Designed for 1" insulating glass
- U-Value: as low as 0.26

### Features

- Nail fin and block frame available
- Ladder pull and type c-lock
- Fully thermally broken
- Anodized, painted, and woodgrain finishes available
- Hinge option available



# ES-LG550

## Pivot Door



Learn More

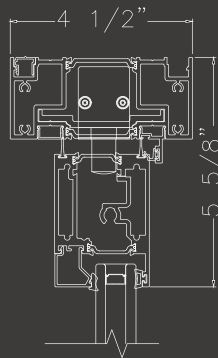
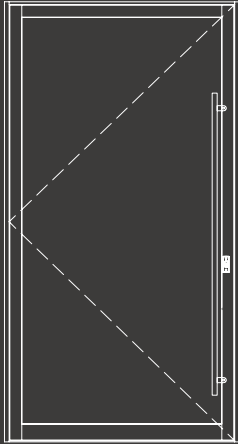

Head with Door Stop

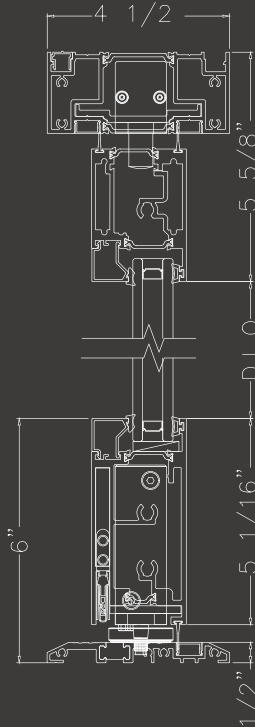

Head and Sill

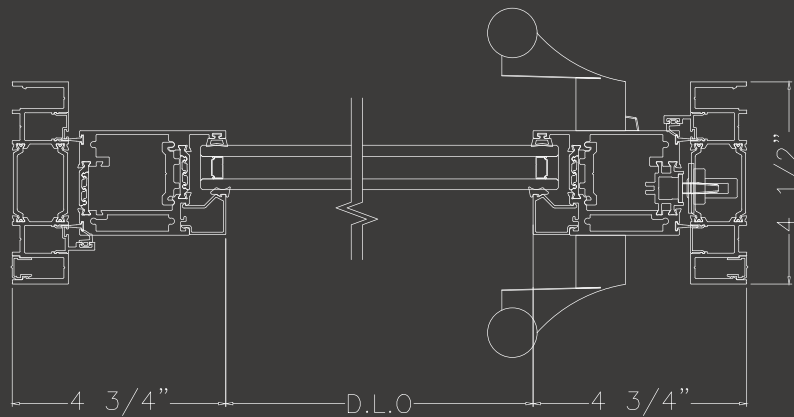

Jamb





# ES-LG450

## Bifold Door

Sleek and contemporary, the Legacy Bifold Door features a thermally broken aluminum system for improved energy efficiency and comfort. Its smooth folding operation creates wide, unobstructed openings that connect indoor and outdoor spaces with ease. With slim sightlines and a refined architectural finish, the ES-LG450 is ideal for high-end residential applications.



### Performance & Highlights

- Frame depth: 4-1/2"
- Frame Sightline for E3: 4-11/16"
- Frame Sightline for E4: 5-3/16"
- Hardware height for E3: Sill 2" and head 2-13/16"
- Hardware height for E4: Sill 2-9/16" and head 3-9/16"
- Designed for 1" insulating glass, 1-3/16" and 1-5/16" insulating laminated glass, and 1-11/16" and 1-13/16" double insulating glass.

### Features

- Folding door hardware option by Centor (E3 and E4 sets available).
- Three point and two point lock mechanism.
- ADA sill available, non water resistance.
- Stacking option with ES-LG225 system.
- Lever Handle option



# ES-LG450

## Bifold Door



Learn More

### E3 Hardware Configuration

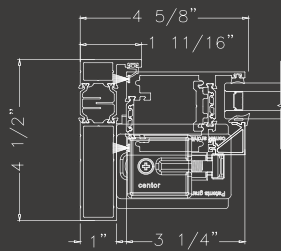
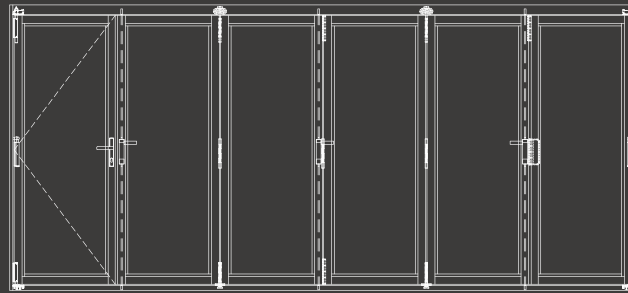

**Jamb  
Pivot Set**

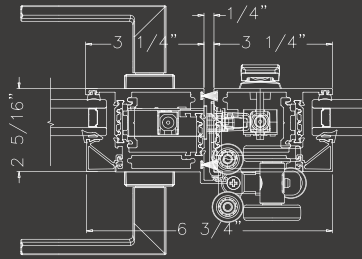

**Astragal  
Left Carrier Set**

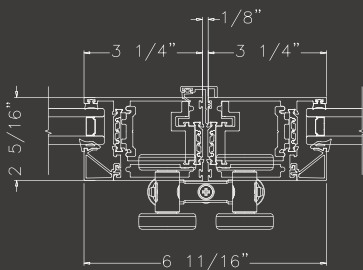

**Hinge Stile**

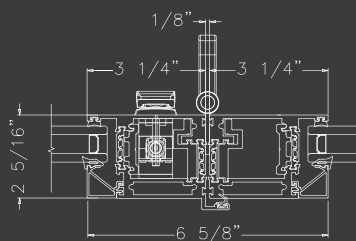

**Hinge Stile  
Dropbolt 2P - Flat Hinge**

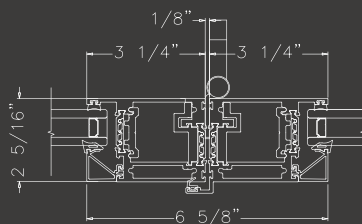

**Hinge Stile  
Offset Hinge**

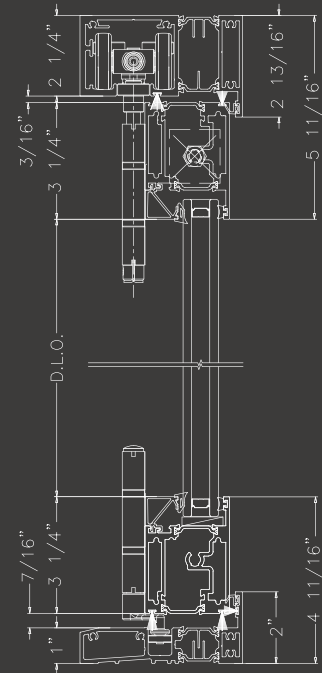

**Sill**

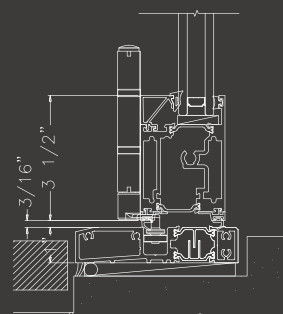

**ADA Sill**





ES | Windows

# Windows that Inspire the Everyday



# ES-LG225

## Window Wall System

A new standard in thermal innovation. With advanced thermal breaks and a U-Factor as low as 0.19, the ES-LG225 combines exceptional efficiency with refined design—ideal for large-scale, modern applications.

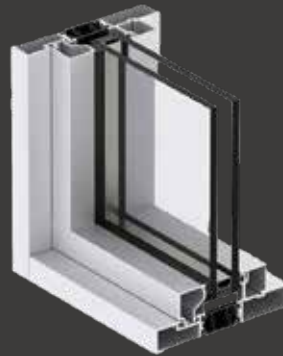

### Performance & Highlights

- Fixed window system
- Pre-assembled and pre-glazed
- Sightline: 1-9/16"
- Frame depth: 4-1/2"
- Maximum sizes:
  - Single Panel: 72" width x 144" height
  - Mulled panels: 60" width x 120" height
- Designed for 1" and 1-1/4" insulated glass; 1-9/16" and 1-19/32" double insulated glass
- Test configuration: 60" x 120"
- CSA A440 Air: Fixed
- U-Value: as low as 0.16

### Features

- Flush frame and fin frame
- Stacking panels available
- Vertical and horizontal intermediate for multiple lites
- Fully thermally broken
- Anodized, painted, and woodgrain finishes available
- High base sill available
- Accessories available



# ES-LG225

## Window Wall



Learn More

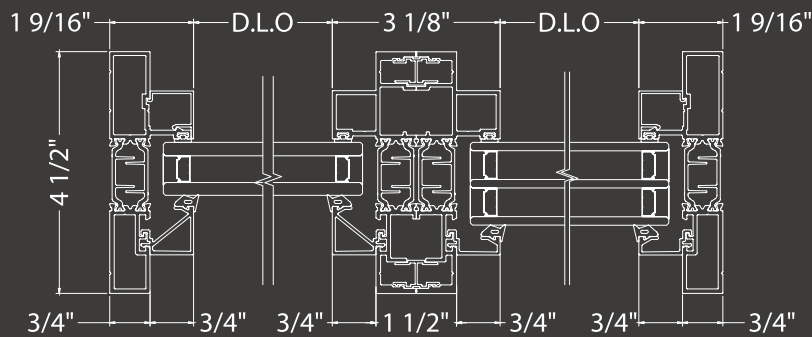
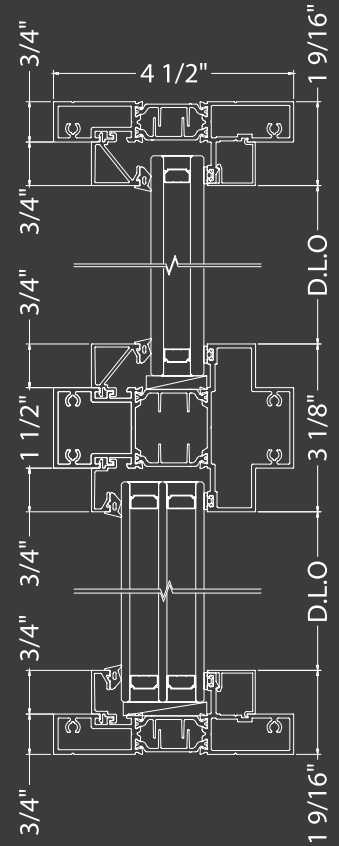
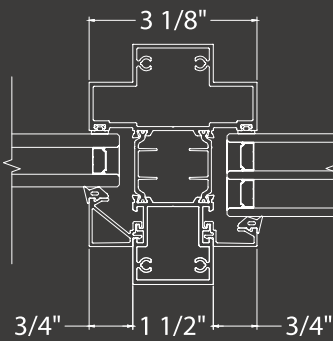
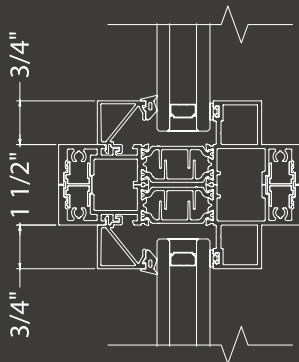
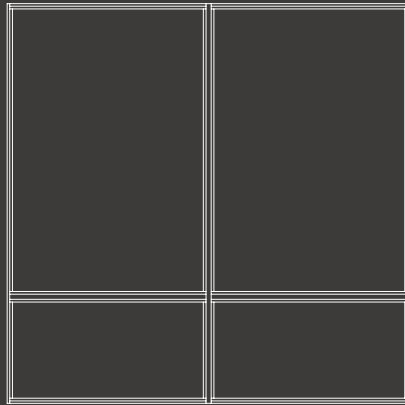

# ES-LG225

## Window Wall



Learn More

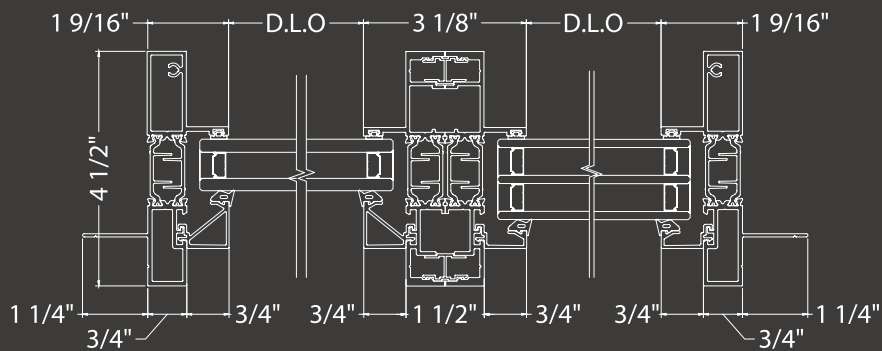
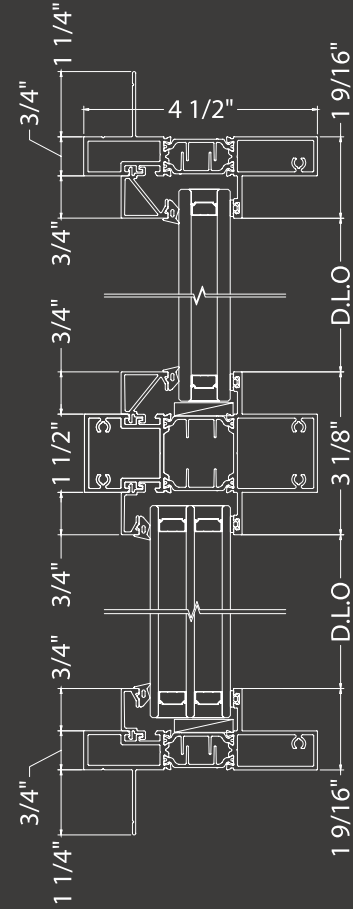
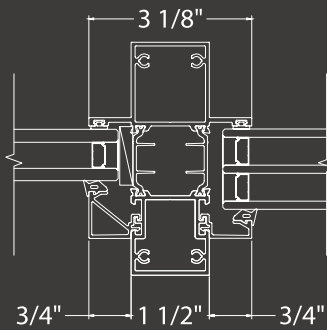
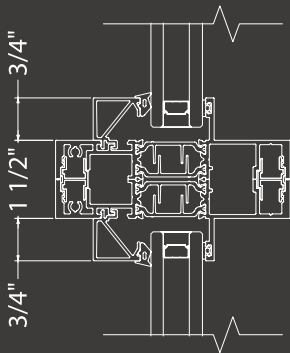
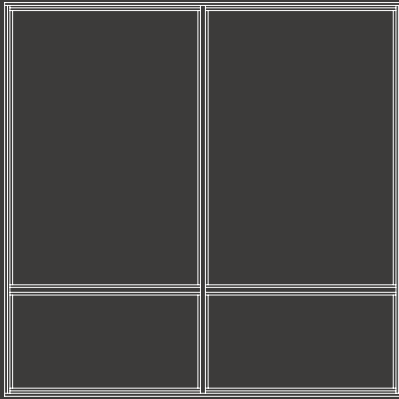





# ES-LG250

## Casement/ Awning Window

Sleek, versatile, and thermally enhanced, the ES-LG250 offers refined functionality with a minimalist profile. Its clean lines and flexible design make it ideal for both contemporary and timeless architecture.

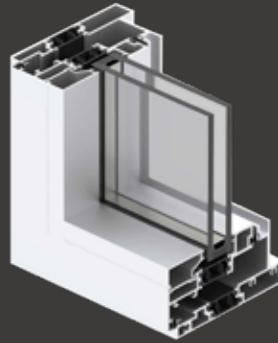

### Performance & Highlights

- Casement and Awning configuration
- Maximum panel size:
  - Casement:
    - 42" width x 72" height
    - 36" width x 84" height
  - Awning: 72" width x 36" height
- Vertical lock:
  - 60" width x 48" height
  - 38" width x 84" height
- Frame depth: 4-1/2"
- Sightline: 2-1/2"
- Design load: +/-40 psf
- U-Value as low as:
  - Casement: 0.26
  - Awning: 0.27
  - U-Value SB70 #2 (Foam): 0.28
- AAMA Rating GW-40
  - 0.27 (3/16" Clear SB70 #2 + 1/2" TPS 90% Argon + 3/16" Clear + 1/2" TPS 90% Argon + 3/16" Low-E Pilkinton #6)

### Features

- Thermal break system for improved performance and insulation
- Available with nail fin anchor
- Stackable (modular) mullion to snap in with Legacy Line systems
- Euro-groove to fit multiple hardware options
- Optional roto-operator to meet ADA requirements



# ES-LG250

## Casement/ Awning Window



Learn More

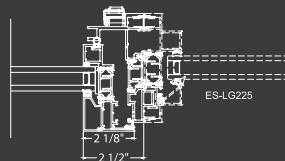
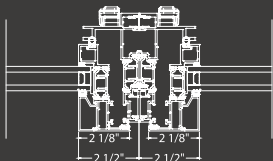
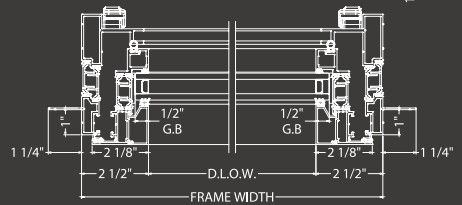
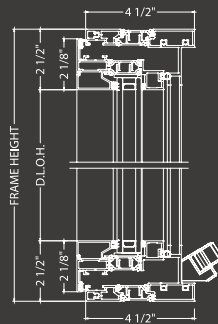
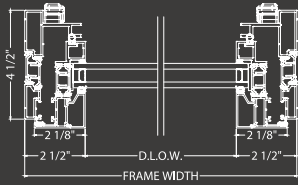
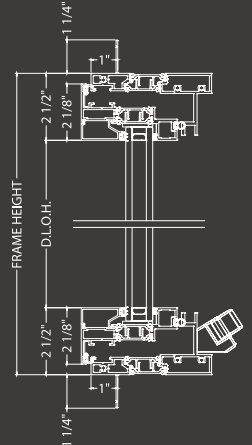
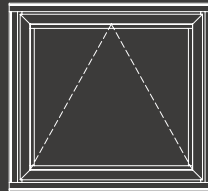
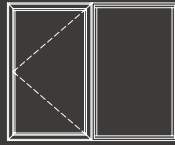
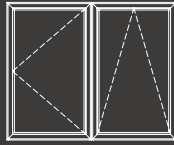
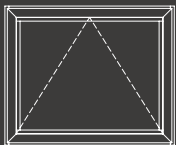
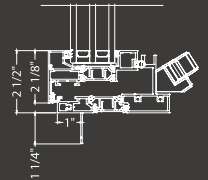
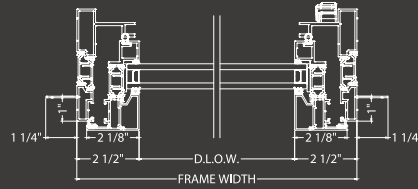
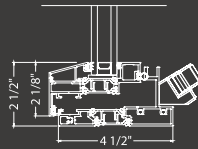
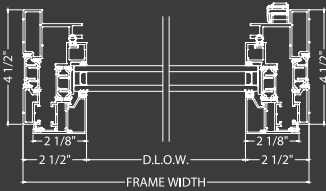
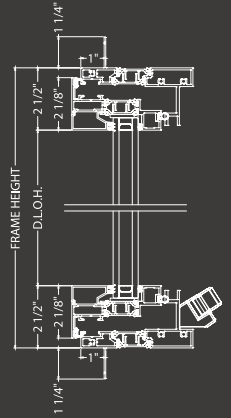
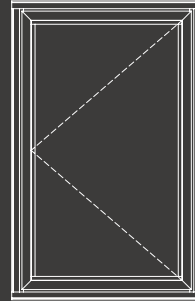
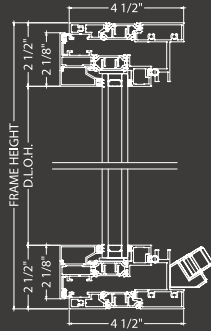
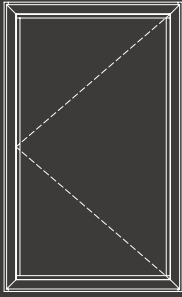



# Color and Finishes

## Color Options (AAMA 2605)



Clear Anodized

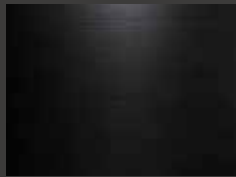

Black Anodized



Bronze Anodized

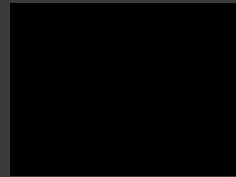

Black

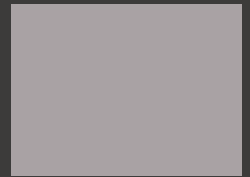

Silver



Birchmount Grey



Synchronicity Beige

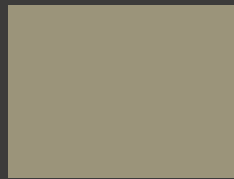

Champagne Bronze

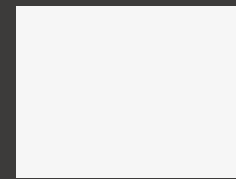

White

## Woodgrain Finishes



**Mahogany**

DS721 SU + 81441/01 L4



**Nogal**

DS733 SU + 81806/05 L4



**Teka**

DS733 SU + 82601/01 L4



**White Oak**

DS745 SU + 82513/04 L4



**Pine**

17G-916-A040 + 81406/01 L4



**Golden Pecan**

17G-937-A040 + 81407-01 L4



**Olive**

DS718S + 81109/04 L4

# Accessories

Every window and door is produced with the finest materials, using the latest technologies and benefiting from the skilled talent of our experienced team. The result is an timeless design with engineered precision and proven performance.

## Flush Mount Handle

ES-LG850



## Peak Handle

ES-LG525



## Ladder Pull

ES-LG550



## Hardware Finishes

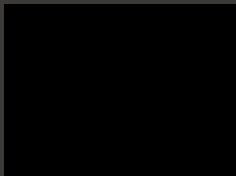

Black

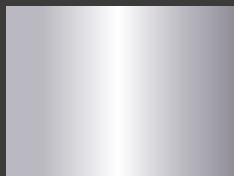

Satin

# Glass Options That Go Beyond

Our Legacy Line features SB70 high-performance insulated glass with Argon for exceptional energy efficiency and comfort. Every pane is tempered for strength and engineered for lasting clarity and protection.

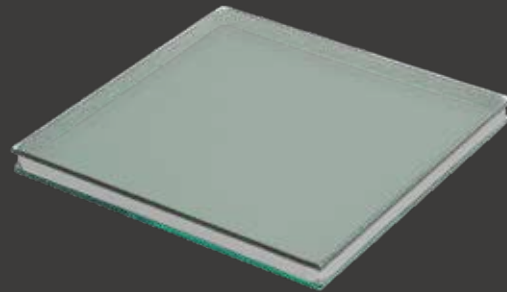

## Key Features

- SB70 with Argon Insulation – Advanced thermal performance for year-round comfort.
- Tempered Glass – Enhanced strength and safety in every pane.
- 1/4" / 1/4" Thickness Option – Added robustness and stability, exceeding typical industry standards.
- Laminated Glass Option – Superior sound reduction and added security.

**Our glass is part of the legacy, from strength to silence to year-round comfort.**

# New Designs are on the Horizon.

- Patio Door
- Sliding Window



# Find us Across the U.S.

Explore our nationwide presence and find the nearest showroom to experience our products up close.



## ES Showrooms

### Miami, FL

645 W Hallandale Beach Blvd, Hallandale Beach, FL

### Naples, FL

3401 Bonita Bch Rd, Bonita Springs, FL

### Destin, FL

12889 Emerald Coast Pkwy, Miramar Beach, FL

### New York City, NY

100 Crosby 502, New York City, NY

### Charleston, SC

525 King Street, Charleston, SC

### Chandler, AZ

2700 S Gilbert Rd Ste 5, Chandler, AZ

### Orange, CA

216 E Chapman Ave, Orange, CA

### Houston, TX

7026 Old Katy Rd, Houston, TX

The information contained herein is the exclusive property of ES, which reserves the right to modify it, including but not limited to designs and specifications, without prior notice.

©2026 ES. All rights reserved.

V-January 2026

**imagine  
extraordinary**

[www.eswindows.com](http://www.eswindows.com)

